



GD4 Series

Installation Instructions

Ver. 000002

1. Safety notices

The GD4 Display should be installed and used according to the provided instructions. Installation and use of the GD4 Display contrary to the recommendations specified in this document may result in loss of warranty and damage to the device, vessel, or operator.



WARNING:

The customer must not disassemble or attempt to service the product. There are no user-serviceable parts. Any changes or modifications will result in voided warranty.



WARNING:

Disconnect battery before starting the installation.



WARNING:

The device has a voltage rating of 12V DC.
Maximum operating voltage is 15V DC.



WARNING:

The positive supply wire (BATTERY+) shall always be connected with a 5A fuse to the positive (+) terminal of the battery.



WARNING:

Before connecting the GD4 Display to a power source, make sure that the device is grounded in accordance with the requirements of this manual. It is not possible to connect the GD4 Display to a circuit with positive grounding.

If you have questions about the installation or doubts about compatibility with other devices contact – info@piktronik.com.

2. Applicable products

This document is applicable to the following products:

Product	Overall dimensions, mm	Panel cut-out, mm	Weight, kg
GD4-10	260 x 177 x 61	248 x 165	2,1
GD4-12	303 x 209 x 63	292 x 198	2,4

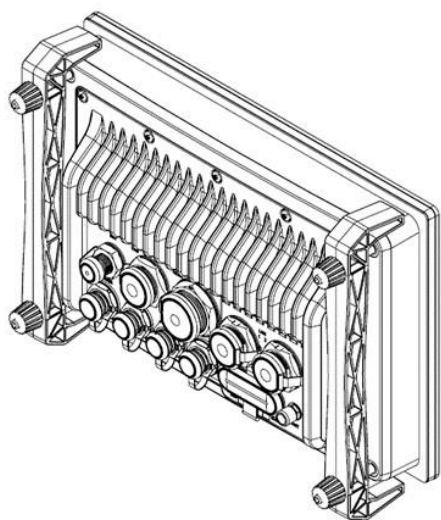

GD4-10 Display (10")

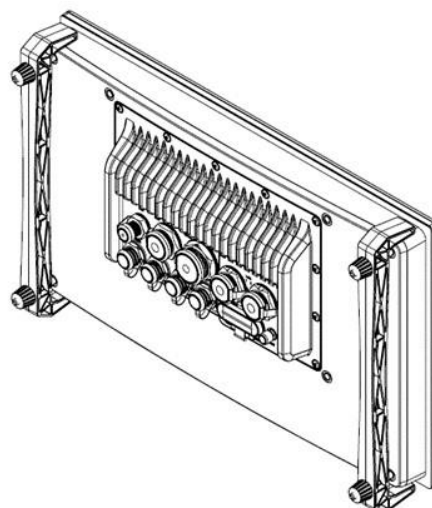

GD4-12 Display (12")

3. Surface mounting

When choosing a location to install the GD4 Display, consider that there should be enough room behind the panel for cable connections as well as for installation and maintenance operations.

Proper air circulation must be provided around the device. The maximum operating temperature of the device is 55°C. Installation shall be designed and executed such that this temperature is not exceeded.

On outdoor installations, ensure that the panel is stiff and flat enough to form a seal with the device, and the intended panel is suitable to bear the weight of the GD4 Display.

In addition, consider that the GD4 Display has an internal GPS/GNSS receiver and 4G modem, which require radio-transparent material around the device to work correctly. Non-radio transparent materials are different types of metal but also carbon fibre laminates. Use an optional GPS/GNSS antenna accessory to enhance GPS reception onboard vessels with enclosed cabins and/or radio frequency-blocking construction, where the GD4 display does not have a clear view of the sky. As the 4G modem antennas are built-in and cannot be exchanged with external equipment, some way of letting the device communicate with the outside world must be arranged.

Note! Whenever the GD4 Display is not in operation, the supplied silicone cover should be used to protect the device from sun and other elements.

1. Cut a hole into the desired surface and insert the GD4 Display through the hole with the gasket in between.

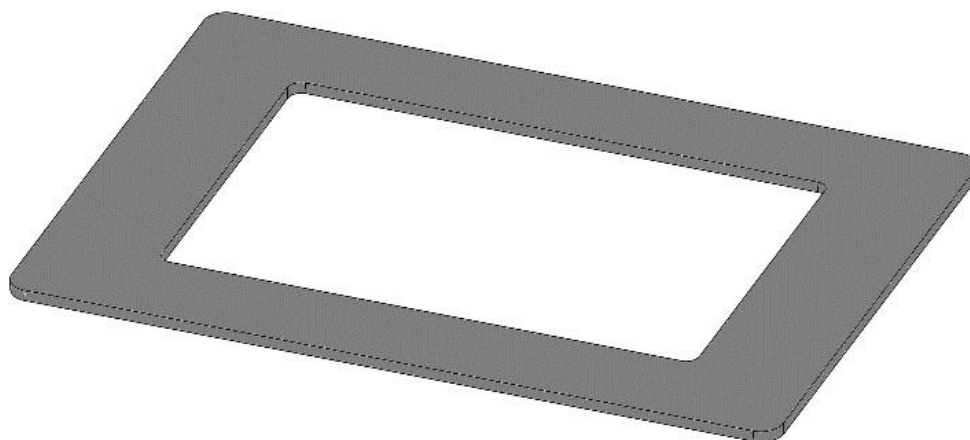

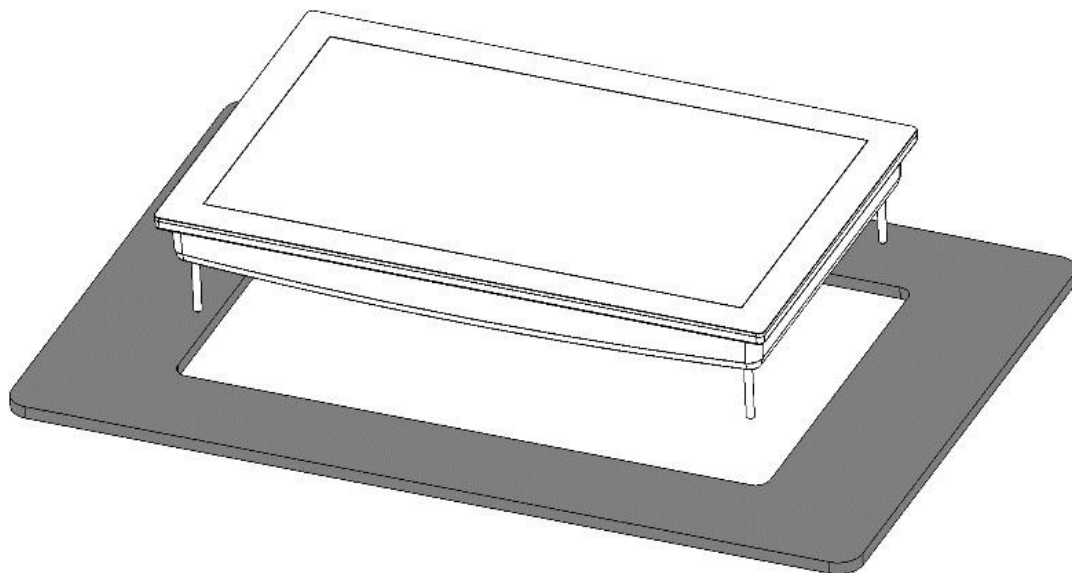

2. After inserting the GD4 display, check that it is properly in place considering the orientation and that the seam around the screen edge is properly sealed on all sides.

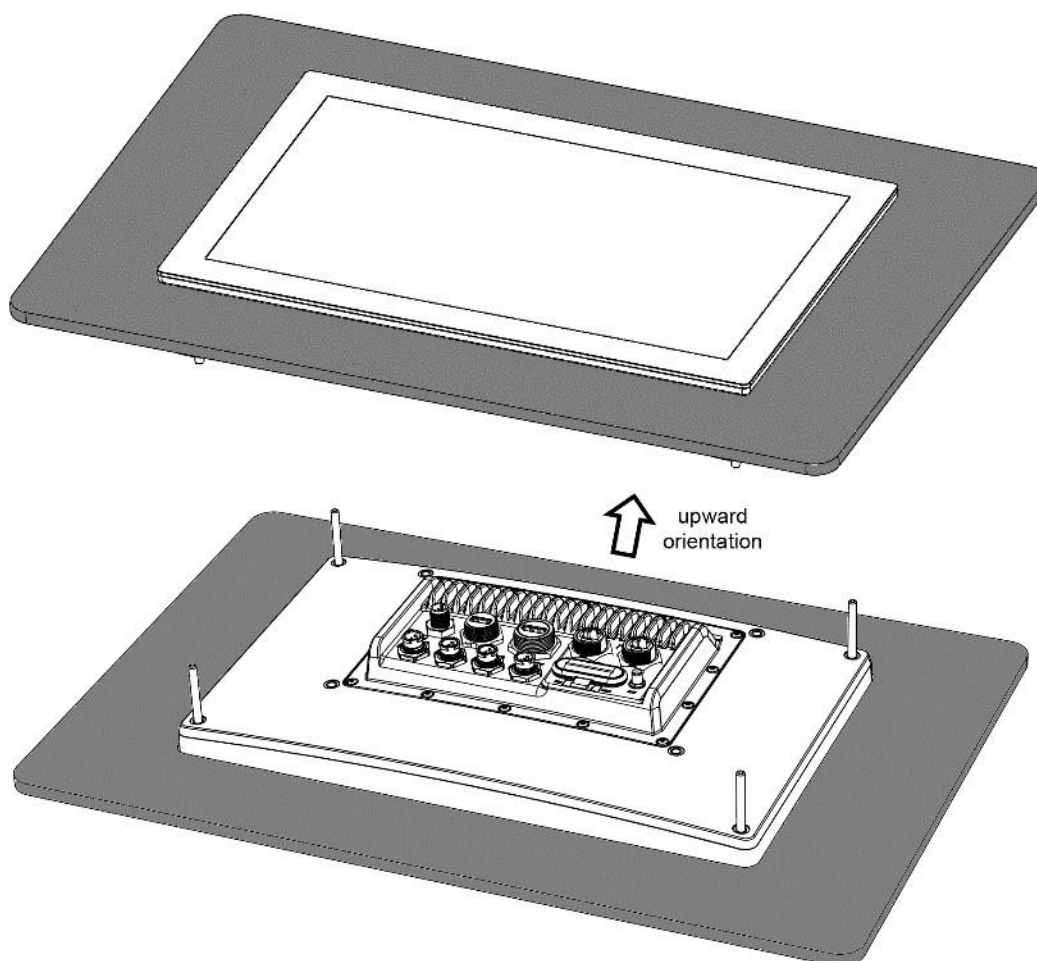

3. Fasten the brackets (supplied with device) with threaded studs and thumb nuts. The nuts shall be tightened carefully by hand to prevent them from loosening due

to vibration, while making sure not to damage the GD4 Display from overtightening.



WARNING:

Do not use tools or overtighten to avoid damage to the device. Max. torque 0.4 Nm.

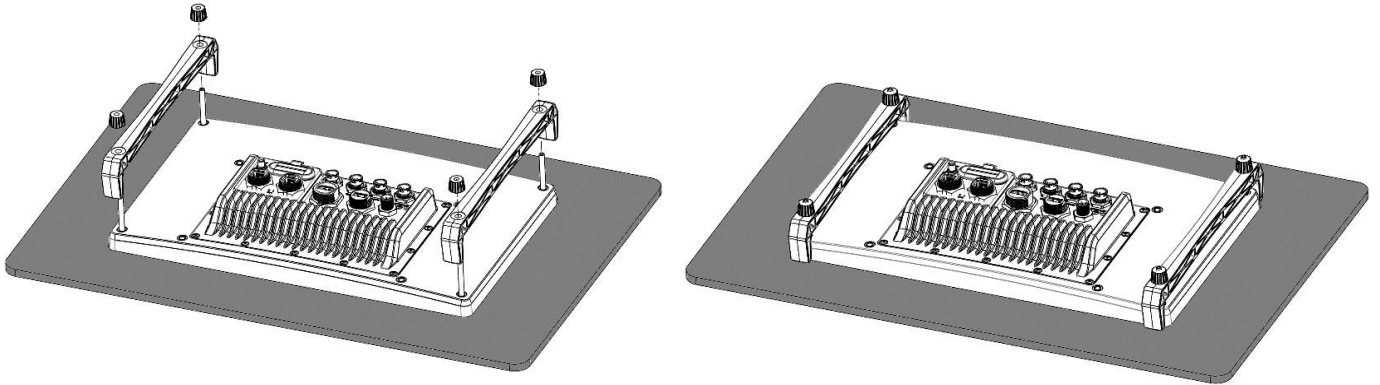

4. Note that extra room should be provided behind a GD4 Display due to the minimum bending radius of cables.

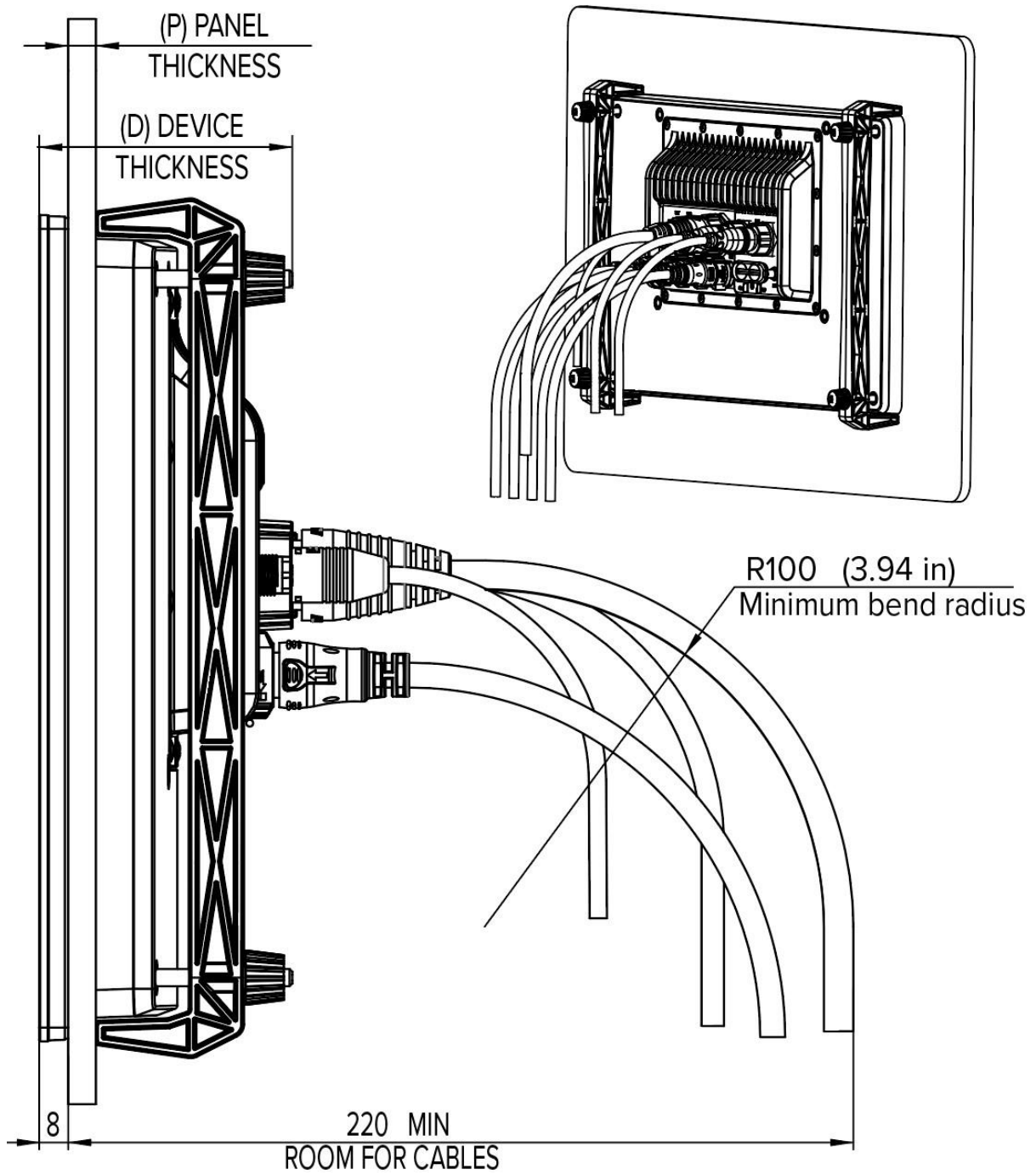

Product	P, mm		D, mm
GD4-10"	4 min	15 max	76 min
GD4-12"		16 max	81 min

5. Protect cables from stress with strain relief clips (not supplied).

4. Bracket (Trunnion) mounting

Optional trunnion bracket can be used to mount the GD4-10" Display (10").

When choosing a location to install the GD4 Display, consider that there should be enough room behind the panel for cable connections as well as for installation and maintenance operations.

Proper air circulation must be provided around the device. The maximum operating temperature of the device is 55°C.

Install the two plastic mounts to the GD4 Display. Maximum torque 0.4 Nm. Use of low strength thread lock is recommended but not necessary.

Use the bracket as a template. Mark and drill at least 4x pilot holes on the mounting surface for the corresponding self-tapping screws (not provided with the bracket).

The side knobs shall be tightened sufficiently by hand to prevent them from loosening due to vibration when underway.

Note! Whenever the GD4 Display is not in operation, the supplied silicone cover should be used to protect the device from sun and other elements.

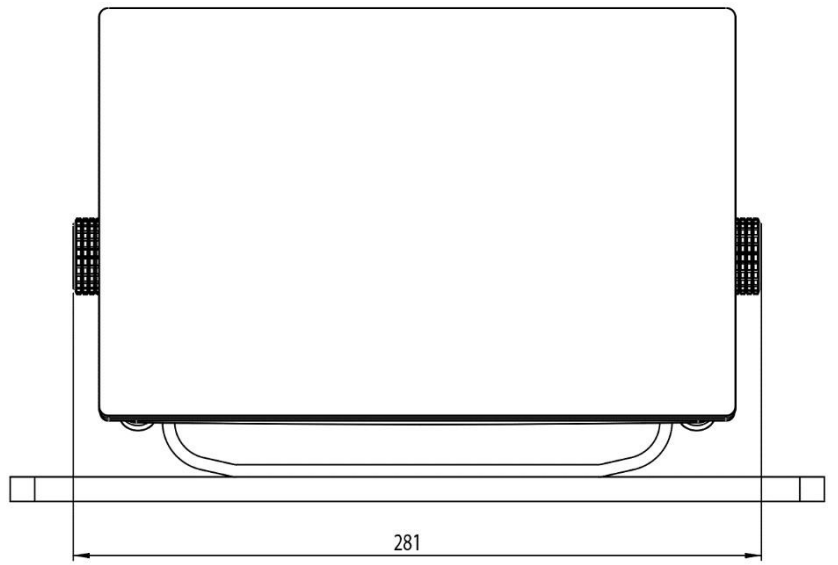
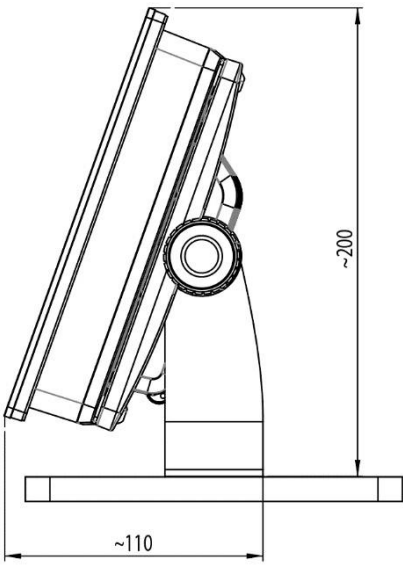
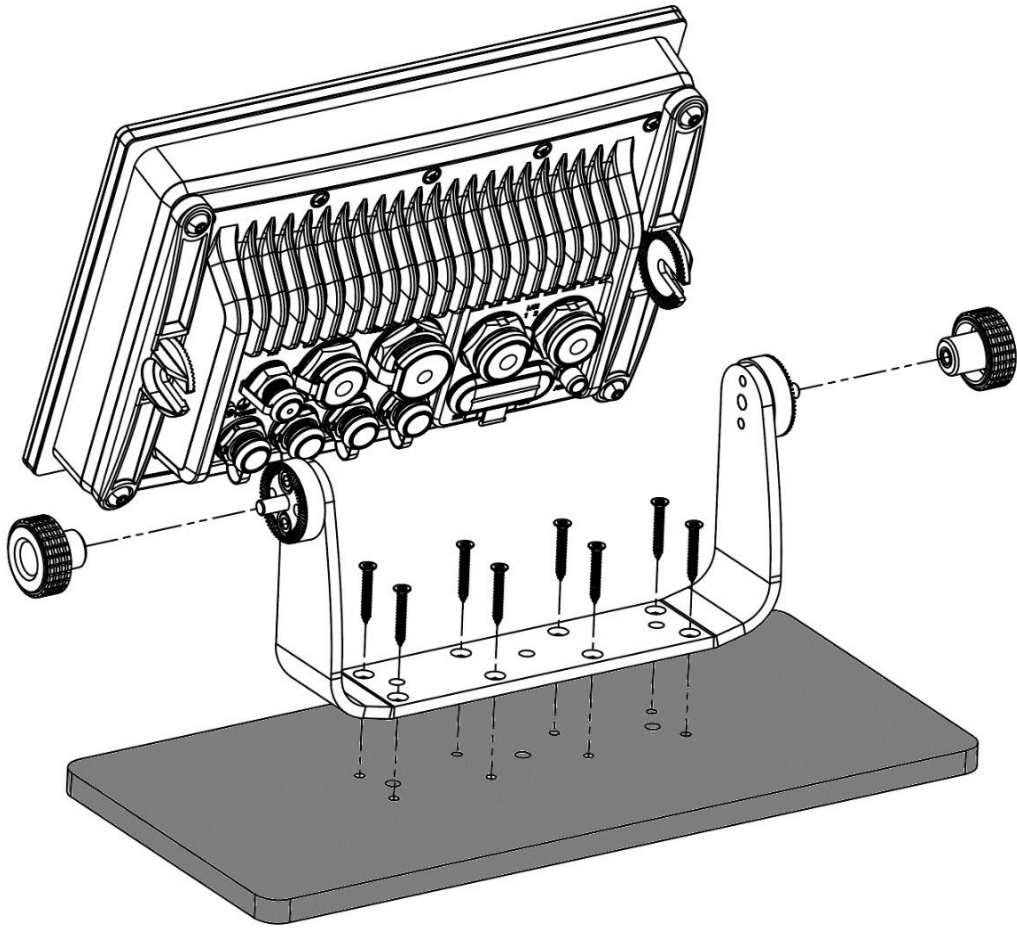

5. Connection's overview

Overview of the GD4 Display connections.

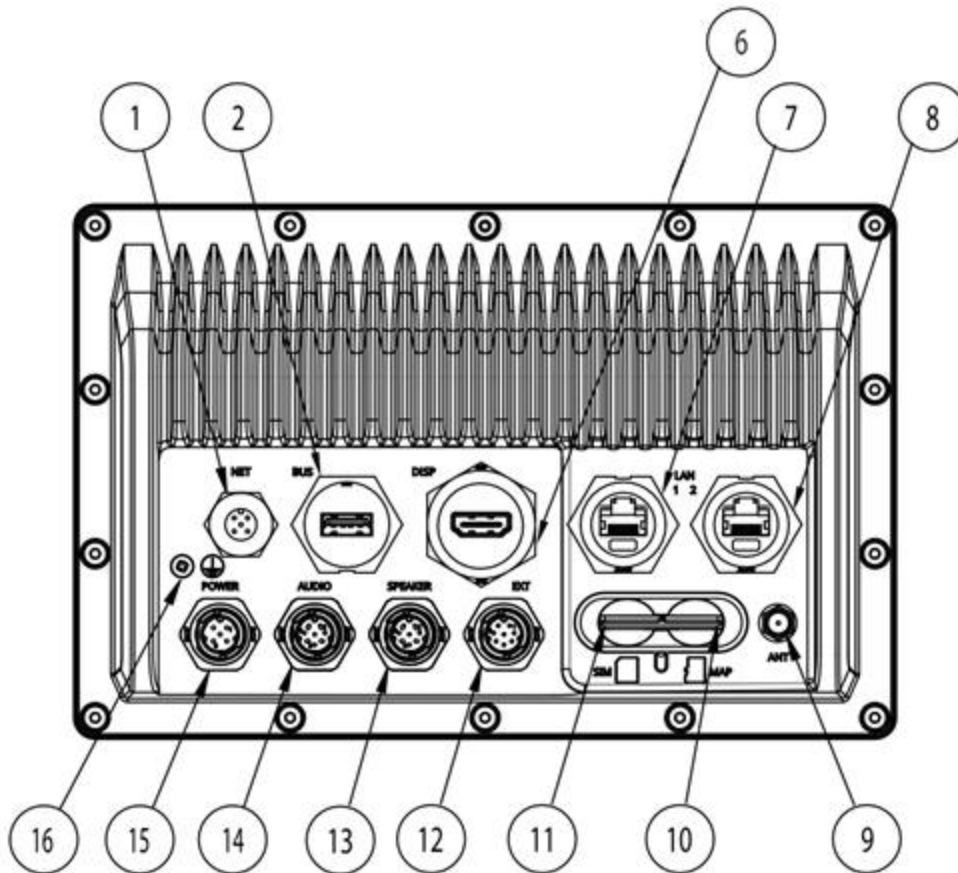

No	NAME	DESCRIPTION
1	NET	NMEA2000 network
2	BUS	Accessory port
6	DISP	Port for auxiliary GD4 Displays
7	LAN1	1000Mbps Ethernet port
8	LAN2	100Mbps Ethernet port
9	ANT	FM/DAB radio antenna connector
10	MAP	Map card holder
11	SIM	SIM card holder
12	EXT	Extension port
13	SPEAKER	Speaker port
14	AUDIO	External line level audio port
15	POWER	Power input
16	Ground	RF ground connector

NOTE:



To **open** "Power", "Audio", "Speaker" and "Ext" caps: pull cap up and towards "NE" direction as shown on the picture below.

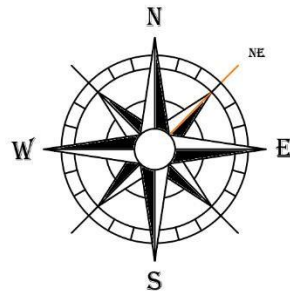
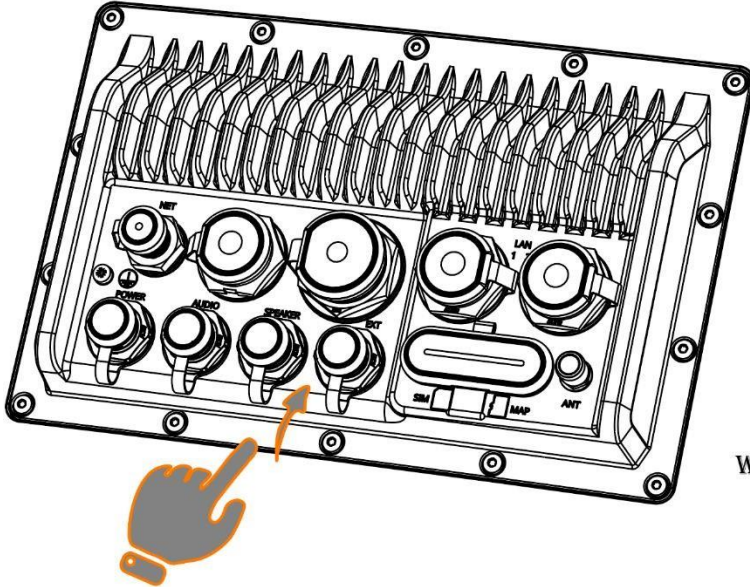

NOTE:



To **close** "Power", "Audio", "Speaker" and "Ext" caps: slide cap towards "NW" direction and push down as shown on the picture below.

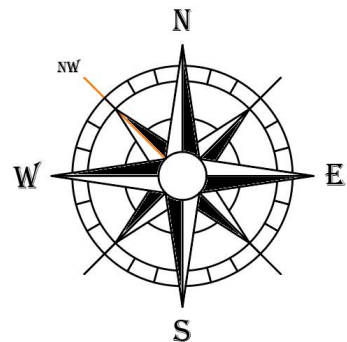
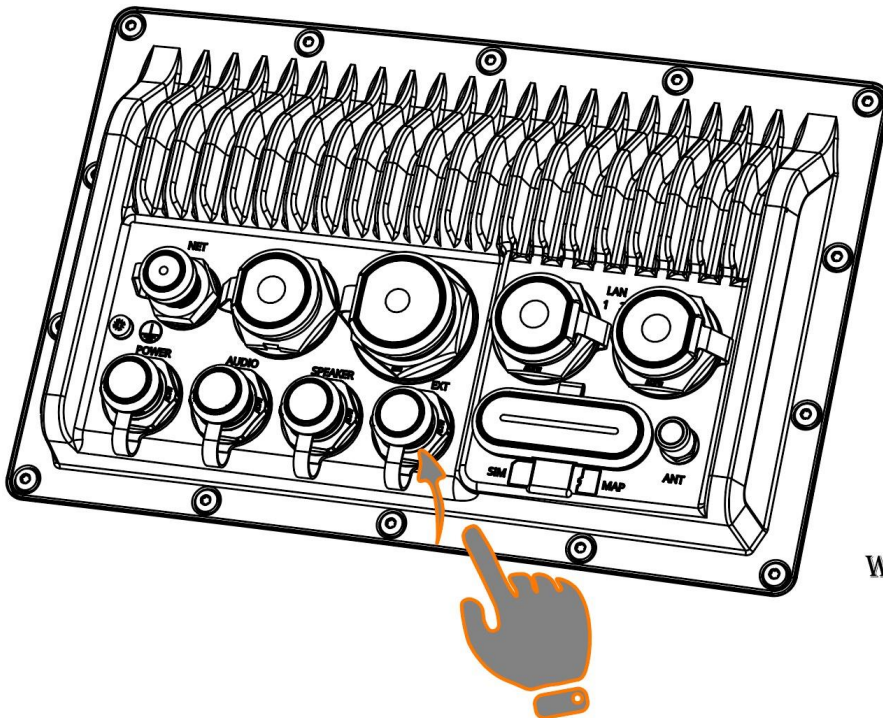

6. Basic installation

6.1. Basic installation connections

Basic installation includes GD4, power supply and NMEA connections.

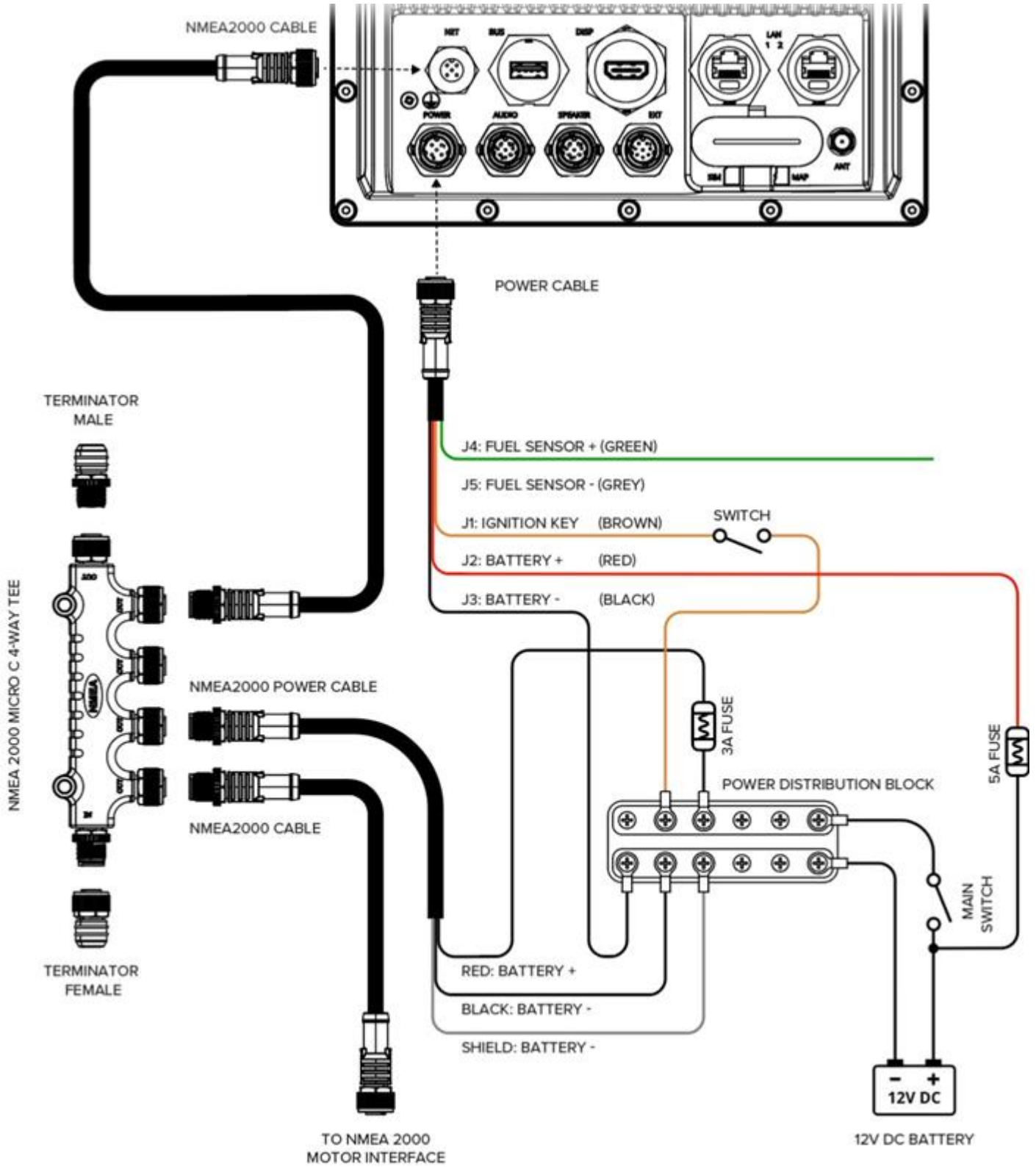

Power connection

GD4 Display is powered by 12V DC via corresponding Q Power cable.

Ensure that the vessel's main power supply is switched off and battery is disconnected.

Connect wire (BATTERY+) to 12V DC power supply positive (+) terminal through a waterproof fuse holder with a 5A fuse (not supplied).

Connect wire (BATTERY-) to 12V DC power supply negative (-) terminal.

Connect wire (IGNITION KEY) through ignition switch to 12V DC power supply positive terminal.



WARNING:

Before applying power to the GD4 Display, ensure that it has been correctly grounded and circuit-protection fuse is installed in accordance with the instructions.

NOTE: The GD4 Display is powered ON and OFF by using switch on IGNITION KEY control signal.

6.2. Grounding — optional dedicated drain wire

Frequencies emitted from devices such as switch mode power supplies or MF/HF transmitters etc. can cause interference with a touchscreen. If you experience issues with touchscreen performance, fitting an additional dedicated drain wire can resolve the issue.

Connect one end of the additional drain wire (not supplied) to your product.

Connect the other end of the additional drain wire to the same point as the power cable drain wire (shield). This might be either boat's RF ground point or the system's negative battery terminal.

The DC power system should be either:

- Negative grounded, where the negative battery terminal is connected to the vessel's ground; or
- Floating, where battery terminal is not connected to the vessel's ground.

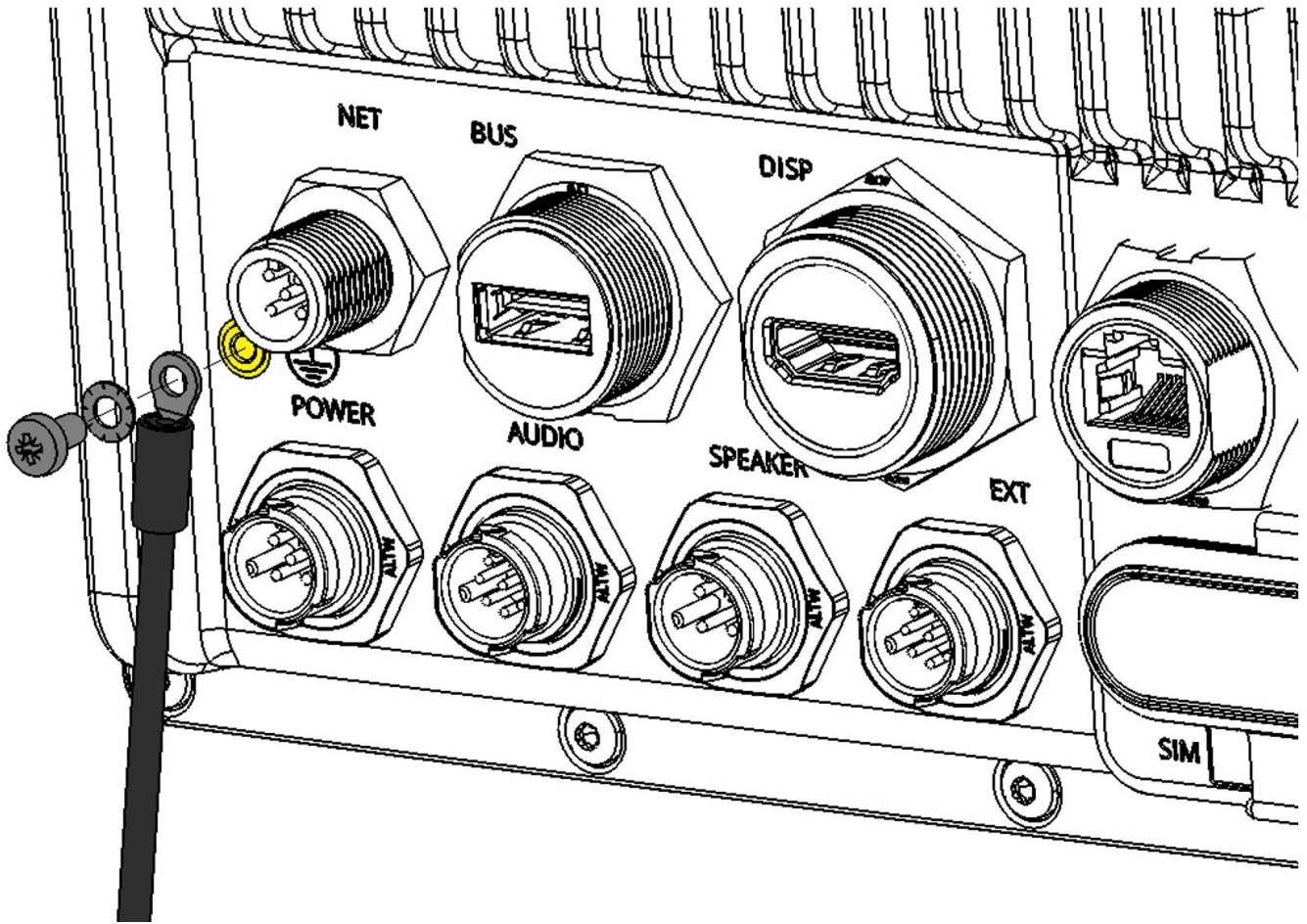

WARNING:

Do not connect the GD4 Display to a system that has positive grounding.

6.3. NMEA Network

NMEA 2000 network is used to receive engine status information to GD4 Display and to communicate with other compatible devices.

1. Mount NMEA2000 MICRO-C 4-WAY TEE (provided separately) to appropriate location. Add terminators to both ends of the multiple-port, another end male terminator and other end female terminator.

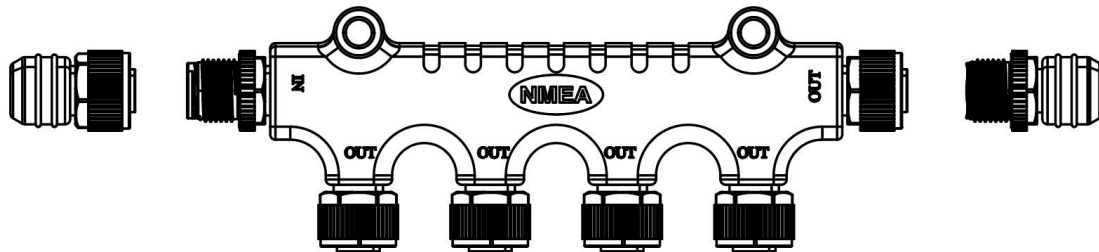

TERMINATOR FEMALE

NMEA 2000 MICRO C 4-WAY TEE

TERMINATOR MALE

2. Connect NMEA 2000 Power cable (provided separately) with 3A fuse to 12V DC power source positive (+) pole, wire and to 12V DC negative (-) pole.

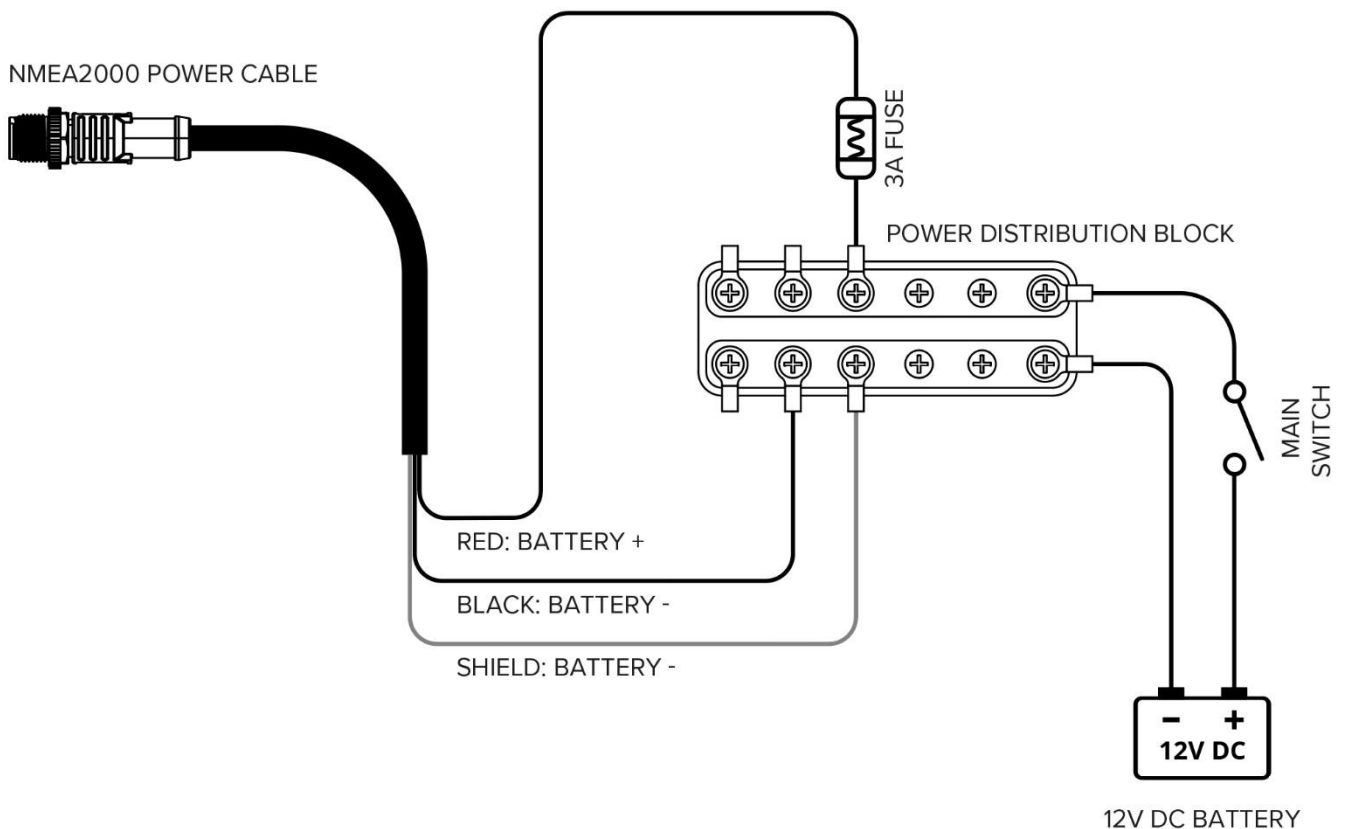

3. Connect one multiple-port output to the GD4 Display NET connector using NMEA 2000 double-ended M/F cable with suitable length (provided separately).
4. Connect one multiple-port output to NMEA Motor Interface using NMEA 2000 double ended cable with suitable length (provided separately).

7. Entertainment installation

Note that GD4 Display has an internal audio amplifier as well as support for two external amplifiers. Two audio zones can be controlled separately:

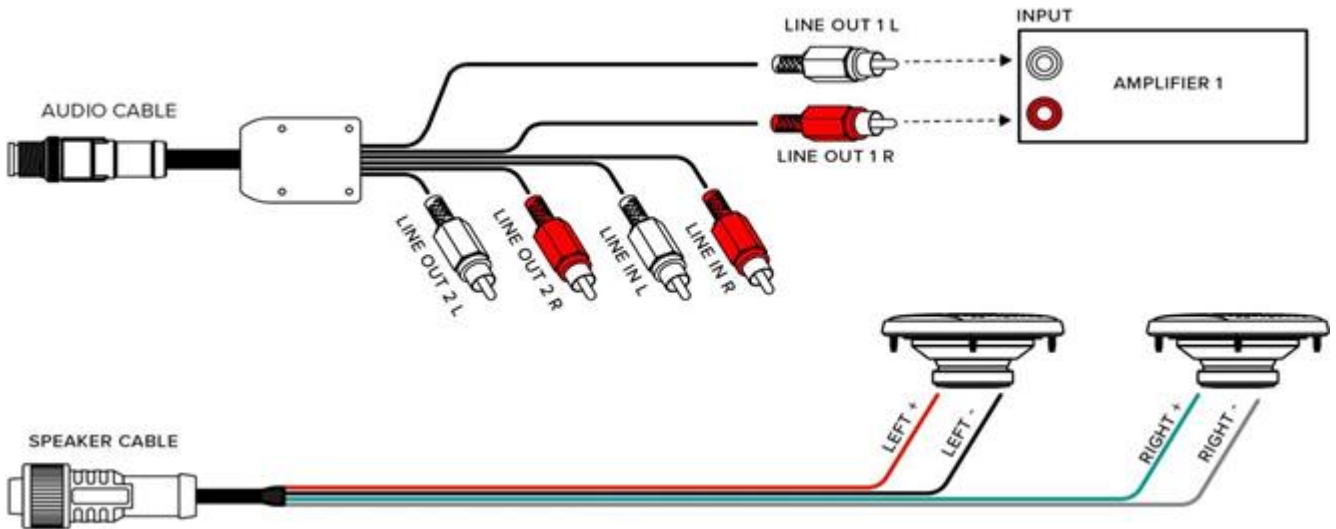

a. Internal amplifier + LINE OUT 1 (external)

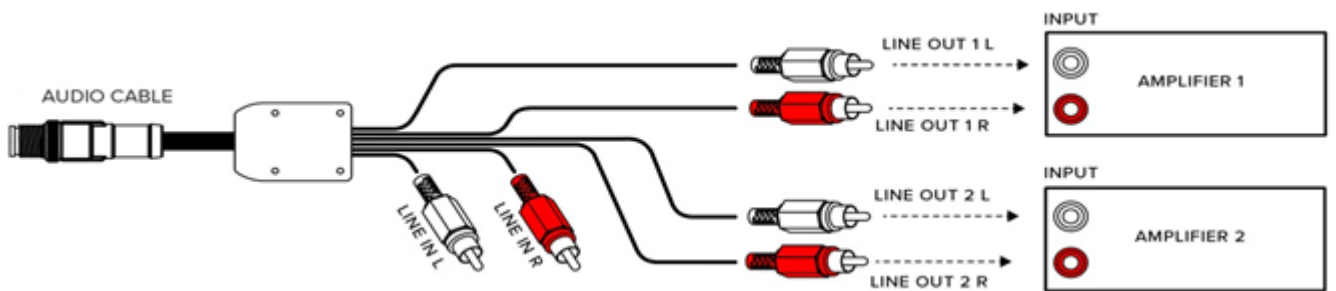

b. LINE OUT 1 (external) + LINE OUT 2 (external)

LINE OUT 2 is connected parallel to internal amplifier signal.

7.1. Speaker connections (Internal amplifier)

Connect GD4 Speaker Cable (provided separately) to the GD4 Display SPEAKER connector.

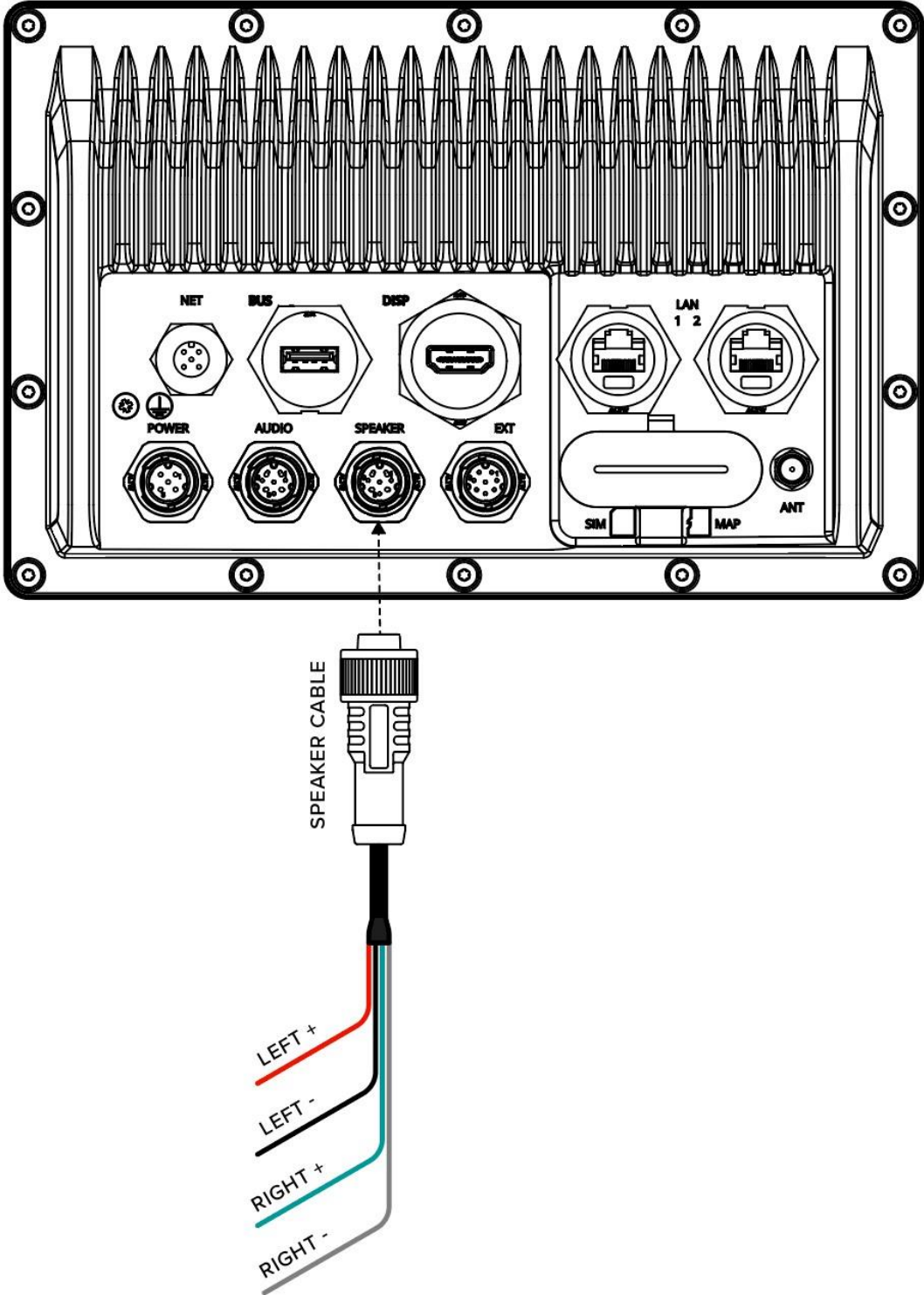

7.2. Audio connections (External amplifier)

Connect Audio Cable (provided separately) to the GD4 Display AUDIO connector.

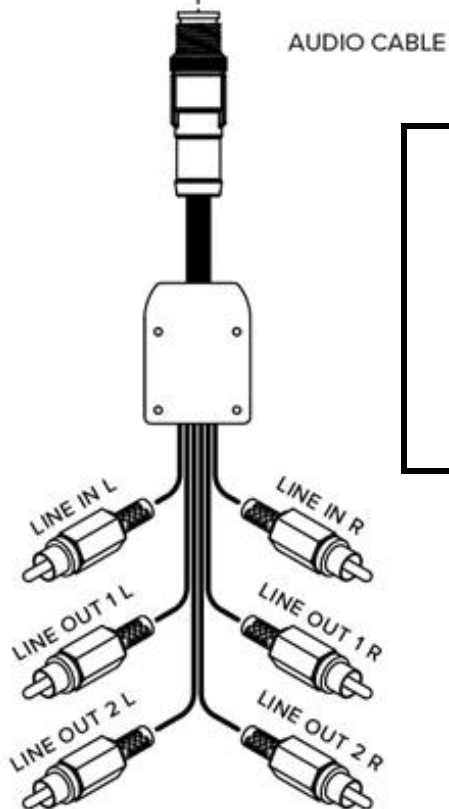
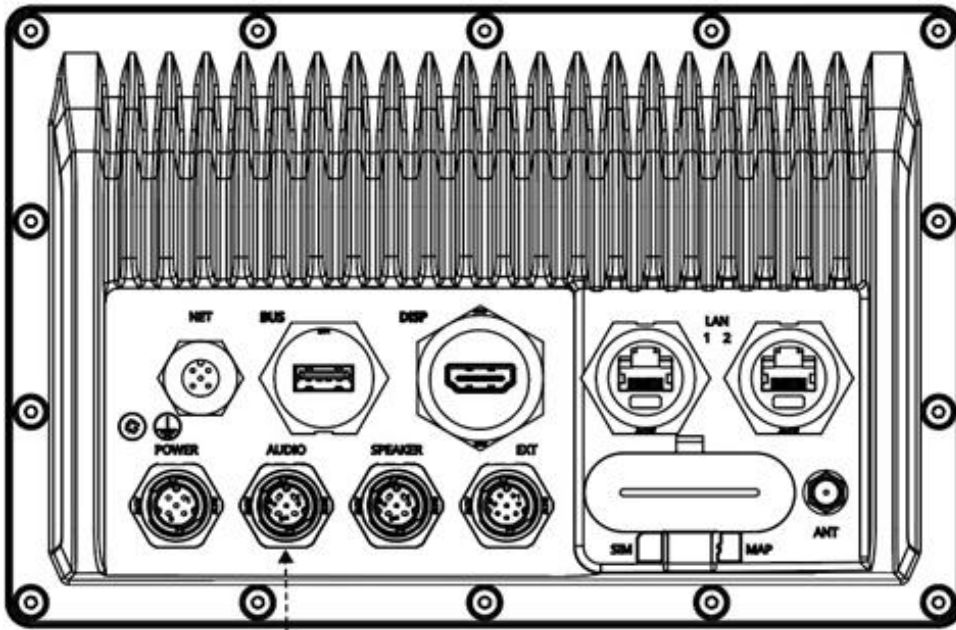

WARNING:

DO NOT connect audio ground (LINE OUTs) to a supply voltage!
This will result in permanent damage to the device.

LINE IN can be used as an auxiliary input, selectable as source in the Music app.

LINE OUT 1 and LINE OUT 2 volume can be controlled separately.

Note that LINE OUT 2 is connected parallel to the internal amplifiers signal.

7.3. FM-antenna connections

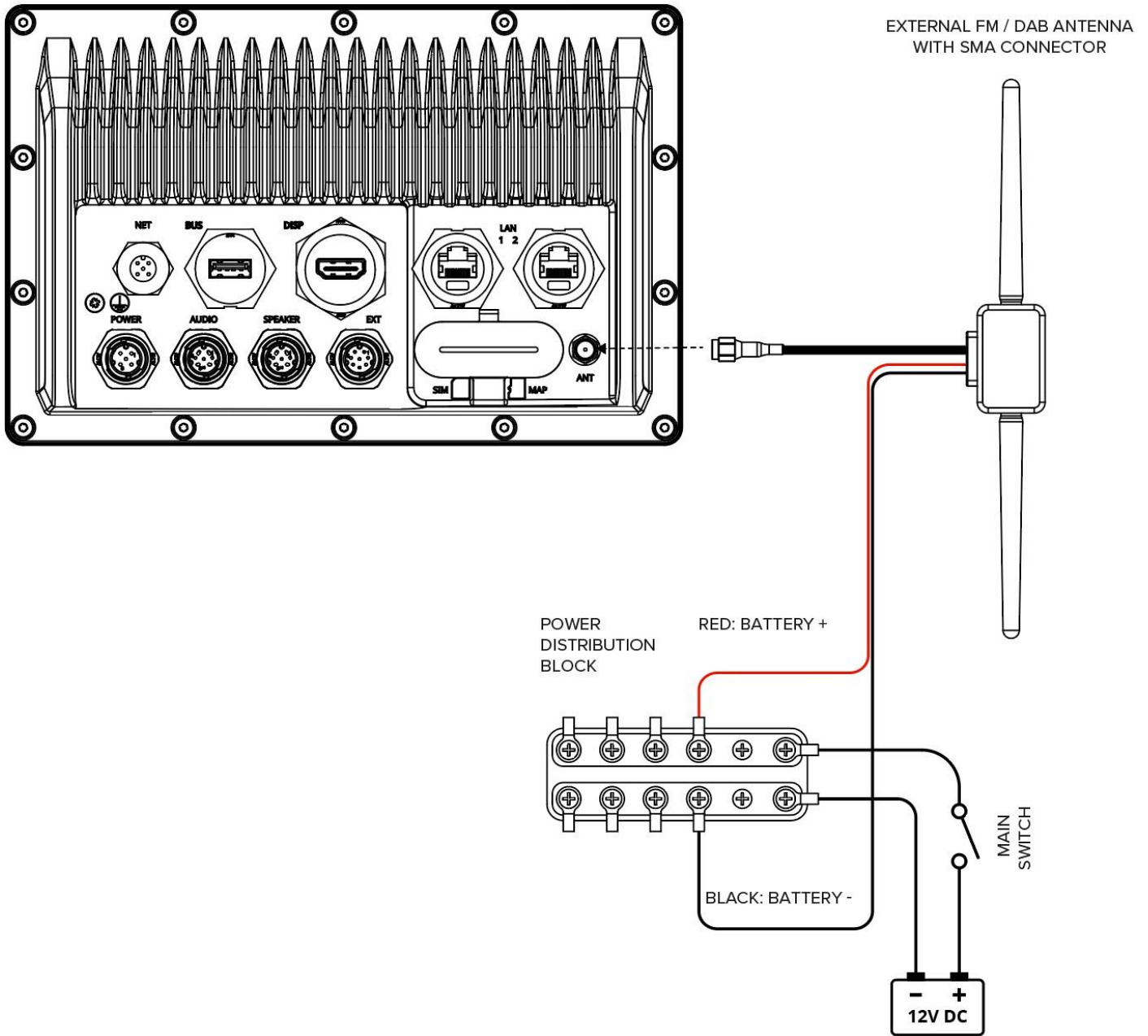

Connect FM/DAB antenna (provided separately) to the GD4 Display ANT connector. You can use FM/DAB antenna with SMA connector, or you can use SMA male to DIN female adapter cable and connect any FM/DAB antenna with DIN male connector to the adapter cable.

9.4. Bluetooth

The GD4 Display can be connected to other devices via Bluetooth to play and control audio and to receive phone calls.

8 Fishfinder installation

The GD4 Display can be connected to a Raymarine CP100 sonar (Fishfinder) and Airmar IC-TM90M Fishfinder.

The Raymarine sonar is connected to either LAN connector with a RayNet adaptor cable RayNet (F) to the RJ45 (M) Port (provided with radar).

The RJ45 connector of the cable shall be assembled with a cable gland (provided separately) to protect the connection against dust and water ingress.

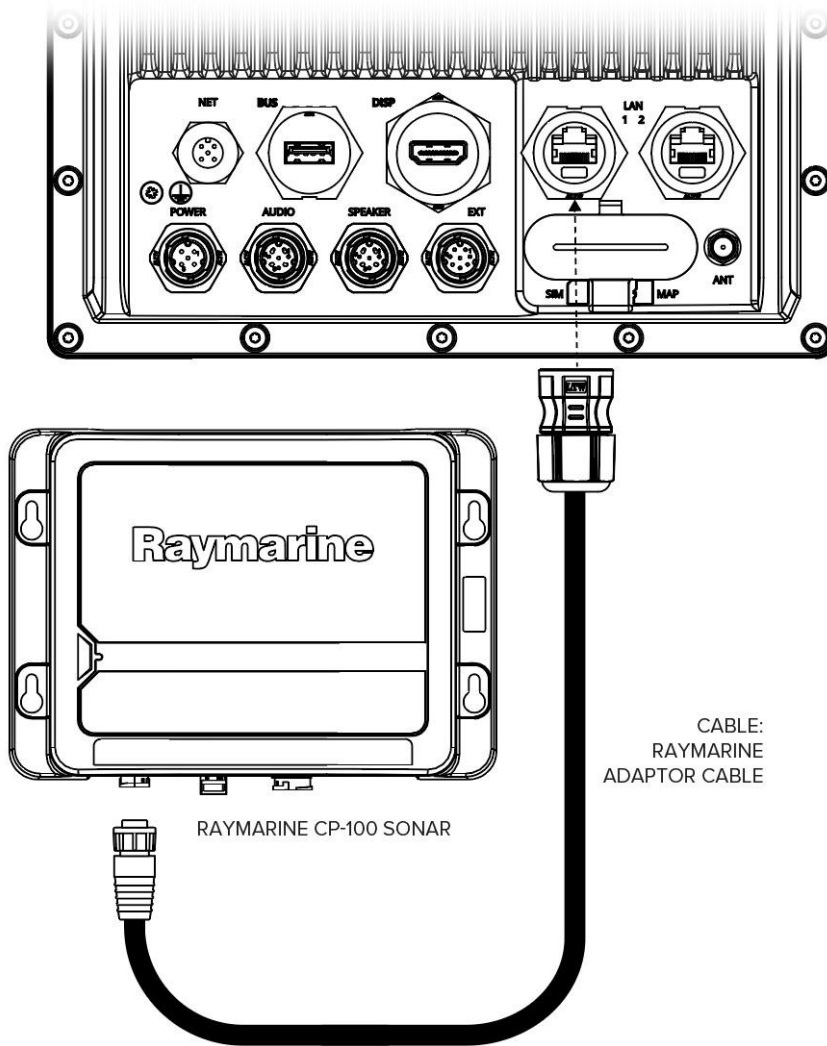

NOTE:

The CP100 sonar might be connected either to one of the two available LAN GD4 display connectors.

The Airmar IC-TM90M Fishfinder has the same electrical connection as the CP100, but it has own fixed RJ45 cable.

9. Radar installation

The GD4 Display can be connected to a Raymarine Quantum Radar. The radar is connected to either LAN connector with a RayNet adaptor cable RayNet (F) to the RJ45 (M) Port (provided with radar).

The RJ45 connector of the cable shall be assembled with a cable gland (provided separately) to protect the connection against dust and water ingress.

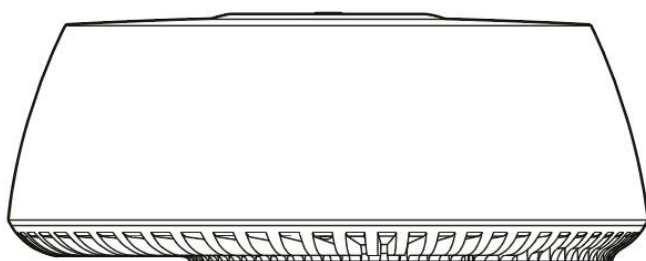
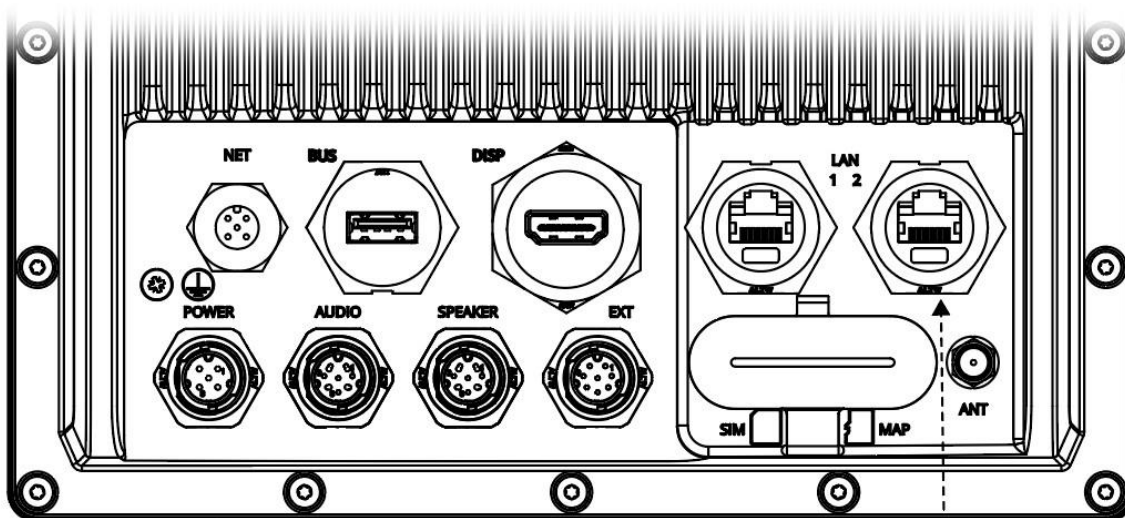

RAYMARINE QUANTUM RADAR

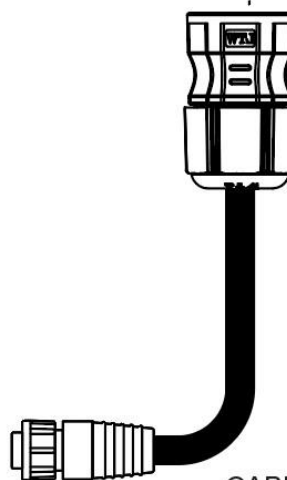

CABLE:
RAYMARINE
ADAPTOR CABLE

10. SIM and MAP cards

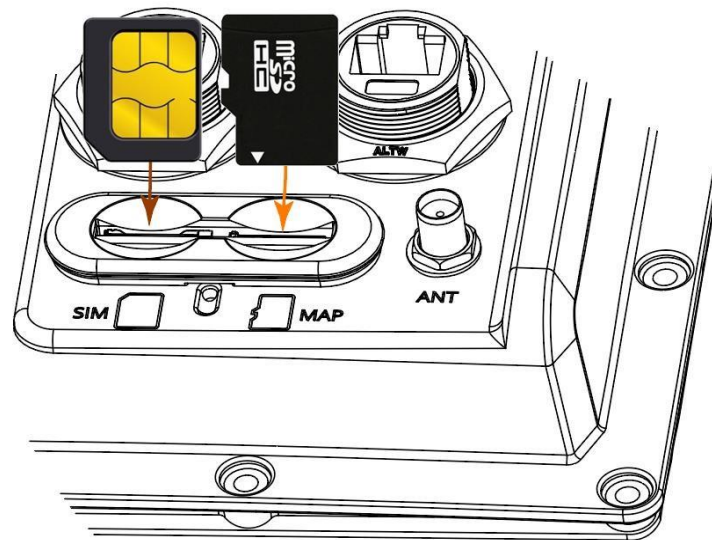

NOTE:

Cards MUST be installed in the orientation shown in the picture above. If installed incorrectly, the slot will break, and the GD4 Display will not work properly.

11. Finalization of the installation

Upon completion of installation work of the GD4 Display it is necessary to check that:

- All connections have been done according to these instructions.
- The device is mounted securely and there are no gaps between the device and the mounting surface.
- Connector sealing caps on the SIM / SD -slots and all unused connectors are fully tightened.



NOTE: Correct positioning of connector caps is crucial for protecting the device.

The geometry of the caps should match the connector geometry.

